

# iEOCR MMEZ-WRUH

Motor protection relay - 0.5..100 A - 100..240 V AC



### Main

Device short name	iEOCR-MMEZ
Product or component type	Protection relay
Protection type	Sensitivity to phase reverse Earth fault, $I_g > I_g$ setting Phase unbalance, 10...50 % Sensitivity to phase loss Locked rotor for running, $I_n > 1.5...5$ times OC setting Locked rotor for starting, $I_n > 2...8$ times OC setting Underload, $I_n < UC$ setting Overload, $I_n > OC$ setting
Product specific application	Motor protection
Network type	AC
Network frequency	50...60 Hz
Communication port protocol	Modbus RTU
Protection adjustment range	0.5...100 A
Tripping threshold	0.5...100 A (definite) 0.03...10 A - earth fault current

### Complementary

[Us] rated supply voltage	100...240 V AC
Mounting support	Flush - display unit Panel - base unit 35 mm DIN rail - base unit
Contacts type and composition	1 NO (selectable GR, AL - O3) 1 NO (logic output - O2) 1 NO (OL/UL - O1)
Short-circuit and overld prot	By 4 A gG fuse
[Ue] rated operational voltage	Power circuit: 690 V AC 50...60 Hz IEC 60947-4-1 Power circuit: 690 V AC 50...60 Hz CSA Power circuit: 600 V AC 50...60 Hz UL
[Uimp] rated impulse withstand voltage	6 kV IEC 60947-4-1
Reset	Automatic reset 0.5...1200 s Electrical < 1 s by interruption of power supply Manual reset
Time delay type	0-Time: 1...30 class (inverse and thermal) U-Time: 0.5...120 s 0-Time: 0.2...120 s (definite) E-Time: 0.05...10 s Ed-Time: 1...30 s, off D-Time: 0...200 s
Display type	7 segments LED Bar graph 4 LEDs
Power consumption per relay	< 3 W
Connections - terminals	Control circuit: 1 cable 1...2.5 mm <sup>2</sup> - flexible - without cable end - M3 Control circuit: 1 cable 1...2.5 mm <sup>2</sup> - flexible - with cable end - M3 Control circuit: 2 cable 1...1.5 mm <sup>2</sup> - flexible - without cable end - M3 Control circuit: 2 cable 1...1.5 mm <sup>2</sup> - flexible - with cable end - M3
Tightening torque	0.8...1.2 N.m for control circuit - cable - 4.7 mm head
Height	56.3 mm

Width	70 mm
Depth	108.1
mm Product weight	0.285 kg

## Environment

Standards	IEC 60947-4-1
IP degree of protection	IP20 IEC 60529
Ambient air temperature for operation	-20...60 °C IEC 60947-4-1
Ambient air temperature for storage	-30...80 °C
Operating altitude	2000 m
Fire resistance	960 °C UL 94 650 °C IEC 60695-2-12
Shock resistance	15 gn for 11 ms IEC 60068-2-7
Vibration resistance	2 gn on 35 mm DIN rail IEC 60068-2-6 4 gn on panel mounting IEC 60068-2-6
Dielectric strength	2 kV at 50...60 Hz in between circuit IEC 60255-5 1 kV at 50...60 Hz in between contact IEC 60255-5 2 kV at 50...60 Hz in between case and circuit IEC 60255-5
Surge withstand	6 kV IEC 61000-4-5
Electromagnetic compatibility	Conducted RF disturbances class A EN 55011 Conducted RF disturbances 10 V EN 61000-4-6 Resistance to fast transient 2 kV IEC 61000-4-4 Resistance to radiated electromagnetic fields 10 V/m level 3 IEC 61000-4-3 Resistance to electrostatic discharge 8 kV air, 6 kV contact IEC 61000-4-2
4-2 [Ith] conventional free air thermal current	3 A, control circuit
Permissible current	250 V, 3 A

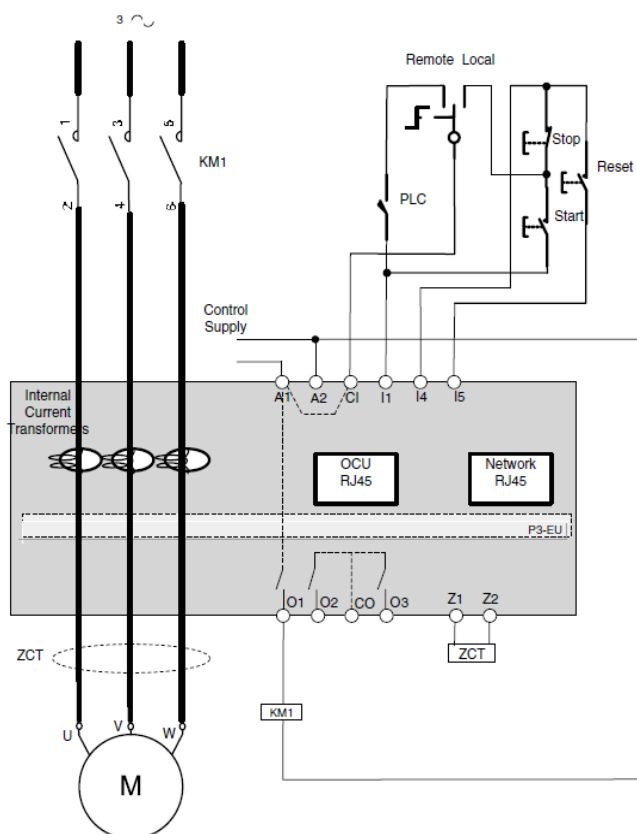

*Typical circuit diagram DOL*